

EDVOTEK® • The Biotechnology Education Company®

Edvo-Kit #

120

Edvo-Kit #120

Ready-to-Load™ DNA Sequencing

Experiment Objective:

The objective of this experiment is to develop an understanding of DNA Sequencing.

See page 3 for storage instructions.

Version 120.210628

EDVOTEK®

1.800.EDVOTEK • www.edvotek.com • info@edvotek.com

Table of Contents

	Page
Experiment Components	3
Experiment Requirements	3
Background Information	4
Experiment Procedures	
Experiment Overview	7
Module I: Agarose Gel Electrophoresis	9
Module II: Staining Agarose Gels Using FlashBlue™	11
Study Questions	12
Instructor's Guidelines	13
Pre-Lab Preparations	14
Experiment Results and Analysis	16
Study Questions and Answers	17
Appendices	18
A EDVOTEK® Troubleshooting Guide	19
B Bulk Preparation of Electrophoresis Buffer and Agarose Gels	20
C Using SYBR® Safe Stain (OPTIONAL)	21

Safety Data Sheets can be found on our website: www.edvotek.com/safety-data-sheets

Technical Support

1.800.EDVOTEK

Mon. - Fri. 8 AM to 5:30 PM EST



Please Have the Following Info:

- Product Number & Description
- Lot Number on Box
- Order/Purchase Order #

1.800.EDVOTEK • info@edvotek.com • www.edvotek.com

www.edvotek.com

- Online Catalog
- Order Products
- Experiment Protocols
- Tech Support
- Resources!



EDVOTEK and The Biotechnology Education Company are registered trademarks of EDVOTEK, Inc. Ready-to-Load, QuickStrip, FlashBlue, and UltraSpec-Agarose are trademarks of EDVOTEK, Inc. SYBR is a registered trademark of Thermo Fisher Scientific.



1.800.EDVOTEK • Fax 202.370.1501 • info@edvotek.com • www.edvotek.com

Duplication of any part of this document is permitted for non-profit educational purposes only. Copyright © 1989-2021 EDVOTEK, Inc., all rights reserved. Version 120.210628

Experiment Components

READY-TO-LOAD™ SAMPLES FOR ELECTROPHORESIS

Components (in QuickStrip™ format)

Store QuickStrip™ samples in the refrigerator upon receipt.

- | | | |
|-------|-------------------|--------------------------|
| A & E | DNA Sequenced "A" | <input type="checkbox"/> |
| B & F | DNA Sequenced "C" | <input type="checkbox"/> |
| C & G | DNA Sequenced "G" | <input type="checkbox"/> |
| D & H | DNA Sequenced "T" | <input type="checkbox"/> |

Check (✓)

Experiment #120 is designed for 8 groups.

Store QuickStrip™ samples in the refrigerator immediately upon receipt. All other components can be stored at room temperature.

REAGENTS & SUPPLIES

Store the following at room temperature.

- | | |
|---------------------------------|--------------------------|
| • UltraSpec-Agarose™ | <input type="checkbox"/> |
| • Electrophoresis Buffer (50x) | <input type="checkbox"/> |
| • Practice Gel Loading Solution | <input type="checkbox"/> |
| • FlashBlue™ DNA Stain | <input type="checkbox"/> |

Requirements

- Horizontal gel electrophoresis apparatus
- D.C. power supply
- Automatic micropipettes with tips
- Balance
- Microwave, hot plate or burner
- Pipet pump
- 250 mL flasks or beakers
- Hot gloves
- Safety goggles and disposable laboratory gloves
- Small plastic trays or large weigh boats (for gel destaining)
- DNA visualization system (white light)
- Distilled or deionized water

All experiment components are intended for educational research only. They are not to be used for diagnostic or drug purposes, nor administered to or consumed by humans or animals.

Background Information

DNA SEQUENCING

DNA sequencing was developed during the 1970's from research groups in the United States and England. Since its early days, these methods have been refined and automated.

There are two basic approaches to DNA sequence analysis. One involves a set of organic chemical reactions while the other uses an enzymatic process. The chemical method is tedious and labor-intensive, whereas the enzymatic approach, which is often called the dideoxy method or Sanger sequencing, is quite fast. The Sanger sequencing method is based on the selective incorporation of chain-terminating dideoxynucleotides by DNA polymerase during in vitro DNA replication.

A specialized cloning vehicle constructed from an *E. coli* virus, called M13, facilitates rapid DNA sequence analysis. This virus contains a polylinker, which is a short region of DNA, about 57 base pairs, containing several unique restriction sites. Segments of DNA to be sequenced are inserted into the polylinker region using standard cloning procedures (Figure 1).

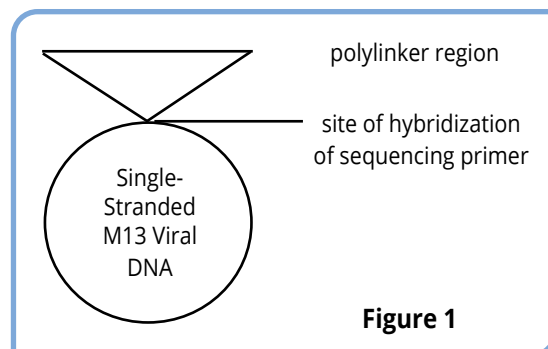

Figure 1

The M13 virus contains a single-stranded circular genome with about 7200 nucleotides. The virus will infect *E. coli* strain JM101 cells which contain a fertility factor. These cells are F+, and male. The virus infects by attachment to the sex pilus. Shortly after infection, the viral DNA will become double-stranded. It is this form which serves as a template for production of single-stranded DNA progeny. The DNA associates with the viral proteins to form mature virus and the virus exits the cell by budding; the cell is not lysed. For cloning and sequencing purposes, double-stranded DNA to be sequenced is inserted into the M13 polylinker region of the DNA intermediate, and then transformed into competent JM101 *E. coli* cells. The transformed cells will begin to produce progeny virus.

To sequence DNA which has been inserted into the polylinker region of M13, single-stranded DNA is prepared from viral plaques. In this experiment, a short 17-base synthetic single-stranded DNA is allowed to hybridize (form a base pairing) with a unique site in M13 adjacent to the polylinker.

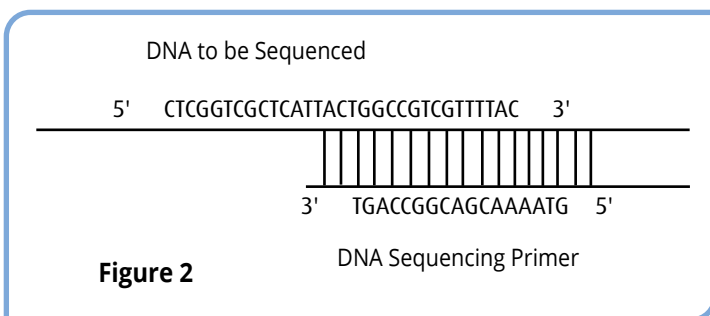

Figure 2

This 17-base oligonucleotide will serve as a primer for DNA synthesis by the Klenow fragment of DNA polymerase I, which lacks the 5'-3' exonuclease activity (Figure 2).

For sequence analysis, four separate enzymatic reactions are performed, one for each nucleotide. Each reaction contains the Klenow fragment of DNA polymerase I, the single-stranded DNA template to which the 17 nucleotide synthetic DNA primer has been hybridized, all four deoxyribonucleotide triphosphates (dATP, dGTP, dCTP, dTTP), 32P-dATP, and the appropriate buffer for in vitro DNA synthesis. The "G" reaction contains dideoxyGTP, the "C" reaction DideoxyCTP, the "A" reaction DideoxyATP, and the "T" reaction DideoxyTTP. Once a Dideoxynucleotide is incorporated into a single strand, DNA synthesis is completely terminated (Figure 3). The site of the Dideoxynucleotide incorporation allows one to determine the

position of that base. The Dideoxynucleotide lacks a 3'-OH group on the ribose ring and it is impossible for the Klenow fragment of DNA polymerase I to add another nucleotide to the growing strand since a 3'-OH group is absolutely required.

Non-isotopic methods using fluorescent dyes and automated DNA sequencing machines have replaced the traditional isotopic methods. In spite of the detection differences, the basic biochemistry of the dideoxy sequencing method is essentially the same.

Since a particular reaction will contain millions of growing DNA strands, a "nested set" of fragments is obtained with each fragment is terminated at a different position corresponding to the random incorporation of the Dideoxynucleotide.

Figure 4 shows the "nested set" of fragments produced for a hypothetical sequence in the "G" reaction. The "G" reaction contains dATP, dCTP, dGTP, dTTP, the Klenow fragment of DNA polymerase, an appropriate solution for DNA synthesis, dATP and a small amount of dideoxyGTP.

As can be seen, ddGTP (dideoxyGTP) incorporation randomly and infrequently will produce a "nested set" of fragments which terminate with a ddGTP. The "nested set" is complementary to the region being sequenced. Similar "nested sets" are produced in the separate "A", "T", and "C" reactions. For example, the "A" "nested set" would terminate with a ddATP.

It should be readily apparent that together the "G,A,T,C" "nested sets" contain radioactive ^{32}P -labeled fragments ranging in size successively from 20 to 29 nucleotides for the hypothetical sequence in Figure 4.

The "G" reaction contains fragments of 20, 24, 28, and 29 nucleotides in length. The first seventeen of these nucleotides are contained in the synthetic DNA sequencing primer. The rest are added by DNA Polymerase I.

POLYACRYLAMIDE SEQUENCING GEL

Traditionally, reaction products from the A, C, G, and T reactions are applied to separate sample wells on a thin vertical polyacrylamide gel, which is usually longer in size (approximately 14 - 18 cm tall). Well # 1 contains the "A" reaction; well # 2 the "C" reaction; well # 3 the "G" reaction; and well # 4 the "T" reaction. The electrophoresis apparatus containing polyacrylamide gel is connected to a power supply with the positive electrode at the bottom and the negative electrode at the top. High voltage is applied (2000 volts, D.C.) to separate the radioactive ^{32}P -labeled fragments which migrate from top to bottom. The

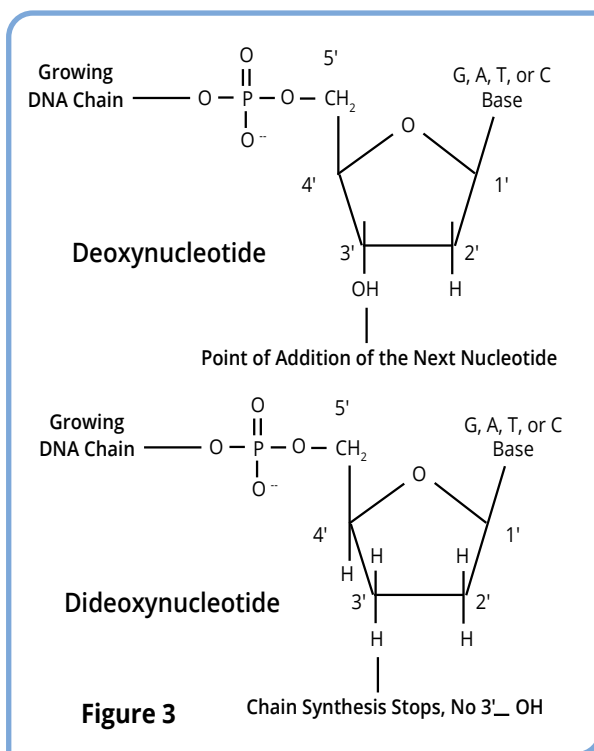

DNA to be Sequenced - Shown in the "G" lane

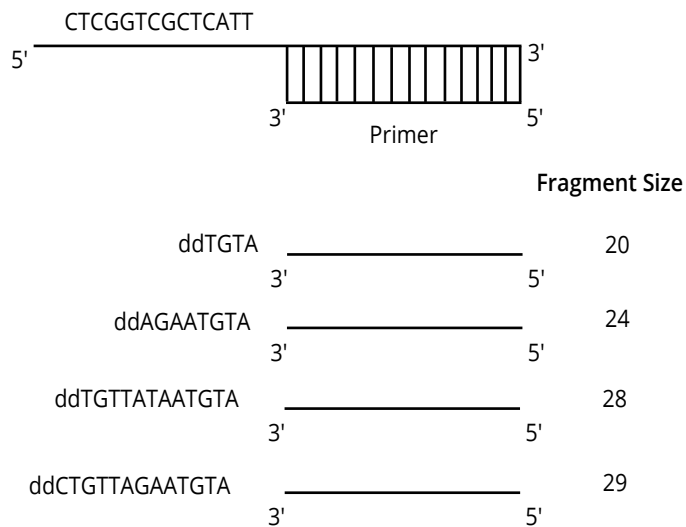
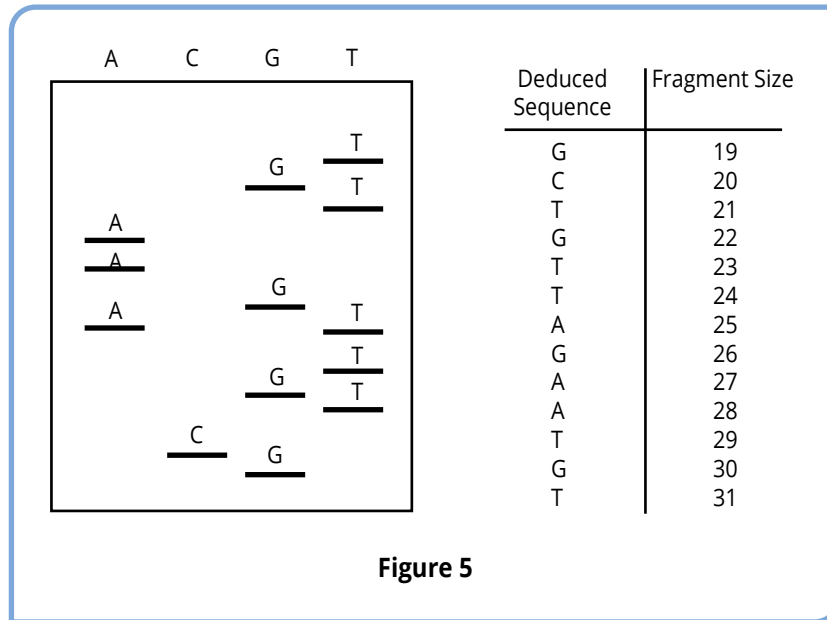

Figure 4

unique sequencing polyacrylamide gels can resolve fragments which differ in size by a single nucleotide, based on size. The smaller fragments move fastest while the larger are slowest.

After electrophoretic separation is complete, autoradiography is performed. The polyacrylamide gel is placed into direct contact with a sheet of x-ray film. Since the DNA fragments are radioactively labeled with ³²P, their position can be detected by a dark exposure band on the sheet of x-ray film. For a given sample well, the horizontal "bands" appear in vertical lanes from the top to the bottom of the x-ray film. Generally, a single electrophoretic run can contain 12 sets of "GATC" sequencing reactions since there are 48 sample wells on a typical gel. A single autoradiograph can yield 1000 nucleotides of novel sequence information. Automated sequence machines will yield several multiples of this information.



Experiment Overview

EXPERIMENT OBJECTIVE

The objective of this experiment is to develop an understanding of DNA Sequencing.

LABORATORY SAFETY

1. Gloves and goggles should be worn routinely as good laboratory practice.
2. Exercise extreme caution when working with equipment that is used in conjunction with the heating and/or melting of reagents.
3. DO NOT MOUTH PIPET REAGENTS - USE PIPET PUMPS.
4. Exercise caution when using any electrical equipment in the laboratory.
5. Always wash hands thoroughly with soap and water after handling reagents or biological materials in the laboratory.



LABORATORY NOTEBOOKS

Scientists document everything that happens during an experiment, including experimental conditions, thoughts and observations while conducting the experiment, and, of course, any data collected. Today, you'll be documenting your experiment in a laboratory notebook or on a separate worksheet.

Before starting the Experiment:

- Carefully read the introduction and the protocol. Use this information to form a hypothesis for this experiment.
- Predict the results of your experiment.

During the Experiment:

- Record your observations.

After the Experiment:

- Interpret the results – does your data support or contradict your hypothesis?
- If you repeated this experiment, what would you change? Revise your hypothesis to reflect this change.

Experiment Overview

MODULE I: Agarose Gel Electrophoresis

Time required: See Table C

Quick Reference for EDVO-Kit #120			
Size of gel casting tray	Groups per gel	Placement of comb	Wells required per group
7 x 7 cm	1 group	1st set of notches	4
10 x 7 cm	1 group	1st set of notches	4
14 x 7 cm	1 group	1st set of notches	4

For this experiment, 10 x 7 cm or 14 x 7 cm gels are highly recommended.

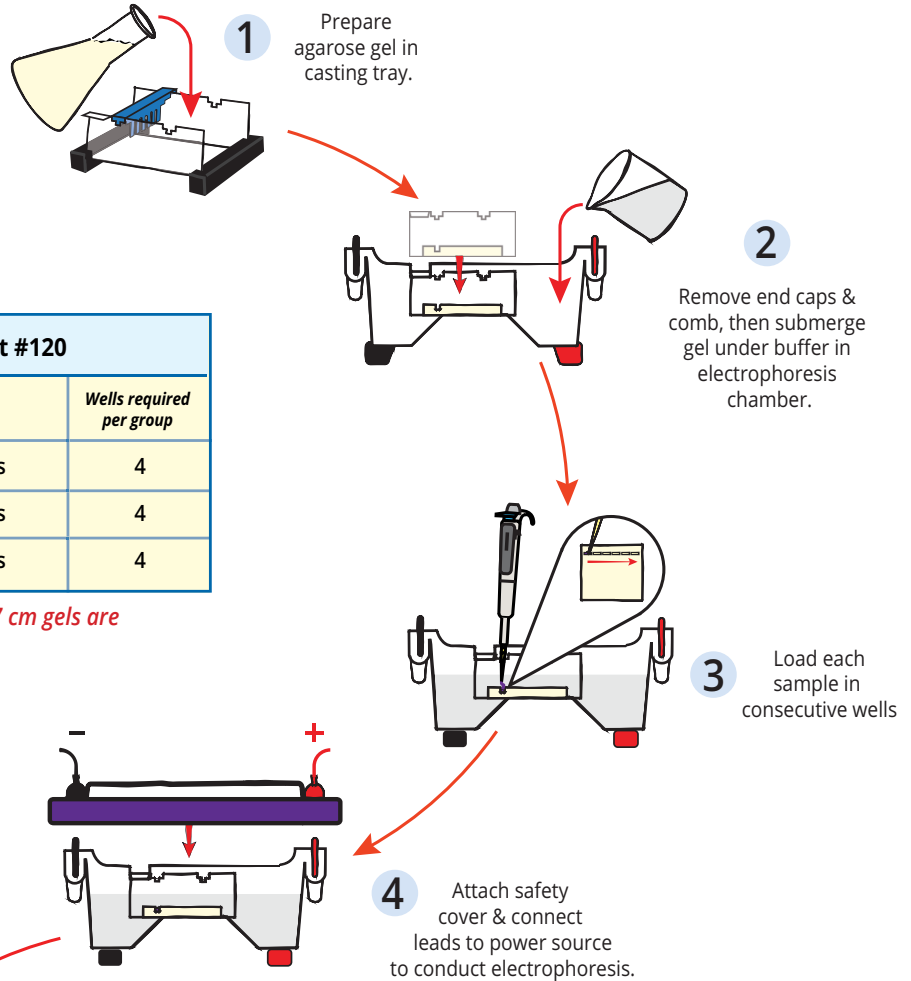

MODULE II: Staining Agarose Gels Using FlashBlue™

Time required: 30 min.

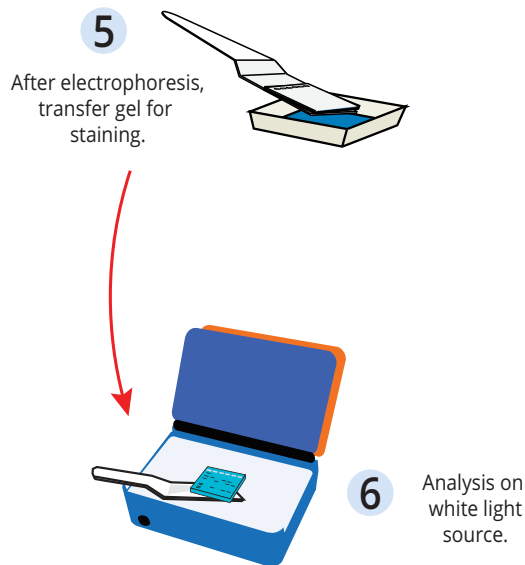

Related EDVOTEK® Instructional Videos

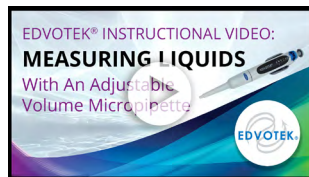

www.youtube.com/edvotekinc

Module I: Agarose Gel Electrophoresis

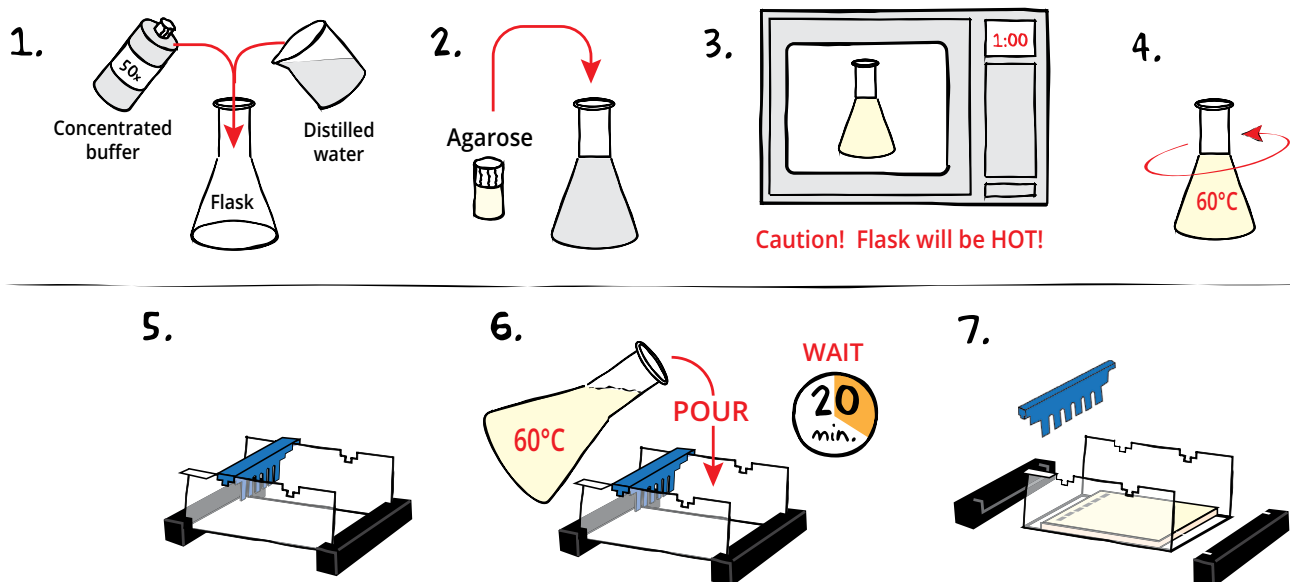

CASTING THE AGAROSE GEL

- DILUTE** concentrated 50X Electrophoresis buffer with distilled water (refer to Table A for correct volumes depending on the size of your gel casting tray).
- MIX** agarose powder with buffer solution in a 250 mL flask (refer to Table A).
- DISSOLVE** agarose powder by boiling the solution. **MICROWAVE** the solution on high for 1 minute. Carefully **REMOVE** the flask from the microwave and **MIX** by swirling the flask. Continue to **HEAT** the solution in 15-second bursts until the agarose is completely dissolved (the solution should be clear like water).
- COOL** agarose to 60 °C with careful swirling to promote even dissipation of heat.
- While agarose is cooling, **SEAL** the ends of the gel-casting tray with the rubber end caps. **PLACE** the well template (comb) in the appropriate notch.
- POUR** the cooled agarose solution into the prepared gel-casting tray. The gel should thoroughly solidify within 20 minutes. The gel will stiffen and become less transparent as it solidifies.
- REMOVE** end caps and comb. Take particular care when removing the comb to prevent damage to the wells.



REMINDER:

Edvo-Kit #120 requires 0.8% agarose gels cast with 4 wells.

For this experiment, 10 x 7 cm or 14 x 7 cm gels are highly recommended.

Size of Gel Casting tray	Concentrated Buffer (50x)	+ Distilled Water	+ Amt of Agarose	= TOTAL Volume
7 x 7 cm	0.6 mL	29.4 mL	0.24 g	30 mL
10 x 7 cm*	0.9 mL	44.1 mL	0.36 g	45 mL
14 x 7 cm	1.2 mL	58.8 mL	0.48 g	60 mL

*Recommended gel volume for the EDGE™ Integrated Electrophoresis System. (Cat. #500).

Module I: Agarose Gel Electrophoresis

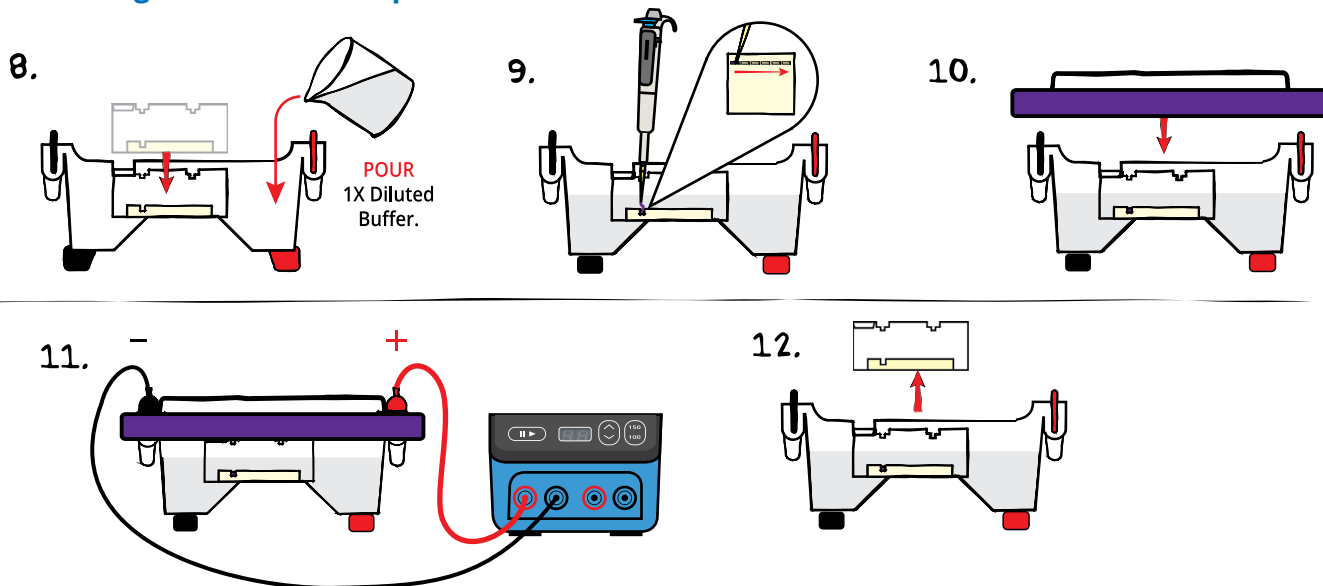

RUNNING THE GEL

8. **PLACE** the gel (still on the tray*) into the electrophoresis chamber. **COVER** the gel with 1X Electrophoresis Buffer (See Table B for recommended volumes). The gel should be completely submerged.
9. **PUNCTURE** the foil overlay of the QuickStrip™ with a pipet tip. **LOAD** the entire sample (35 µL) into the well in the order indicated by Table 1, at right.
10. **PLACE** safety cover on the unit. **CHECK** that the gel is properly oriented. Remember, the DNA samples will migrate toward the positive (red) electrode.
11. **CONNECT** leads to the power source and **PERFORM** electrophoresis (See Table C for time and voltage guidelines). Allow the tracking dye to migrate at least 3 cm from the wells.
12. After electrophoresis is complete, **REMOVE** the gel and casting tray from the electrophoresis chamber.

REMINDER:
Before loading the samples, make sure the gel is properly oriented in the apparatus chamber.

Lane	Tube	DNA Sequenced
1	Tube A	DNA Sequenced "A"
2	Tube B	DNA Sequenced "C"
3	Tube C	DNA Sequenced "G"
4	Tube D	DNA Sequenced "T"

PROCEED to Module II: Staining Agarose Gels Using FlashBlue™.

EDVOTEK Model #	Total Volume Required	Dilution	
		50x Conc. Buffer	+ Distilled Water
EDGE™	150 mL	3 mL	147 mL
M12	400 mL	8 mL	392 mL
M36	1000 mL	20 mL	980 mL

Volts	Electrophoresis Model	
	EDGE™	M12 & M36
	Min/Max (minutes)	Min/Max (minutes)
150	10/20	20/35
125	N/A	30/45
100	15/25	40/60

*Gels that have previously been removed from their trays should be "anchored" back to the tray with a few drops of molten agarose before placing into the electrophoresis chamber. This will prevent the gels from sliding around in the trays and the chambers.

Module II: Staining Agarose Gels Using FlashBlue™

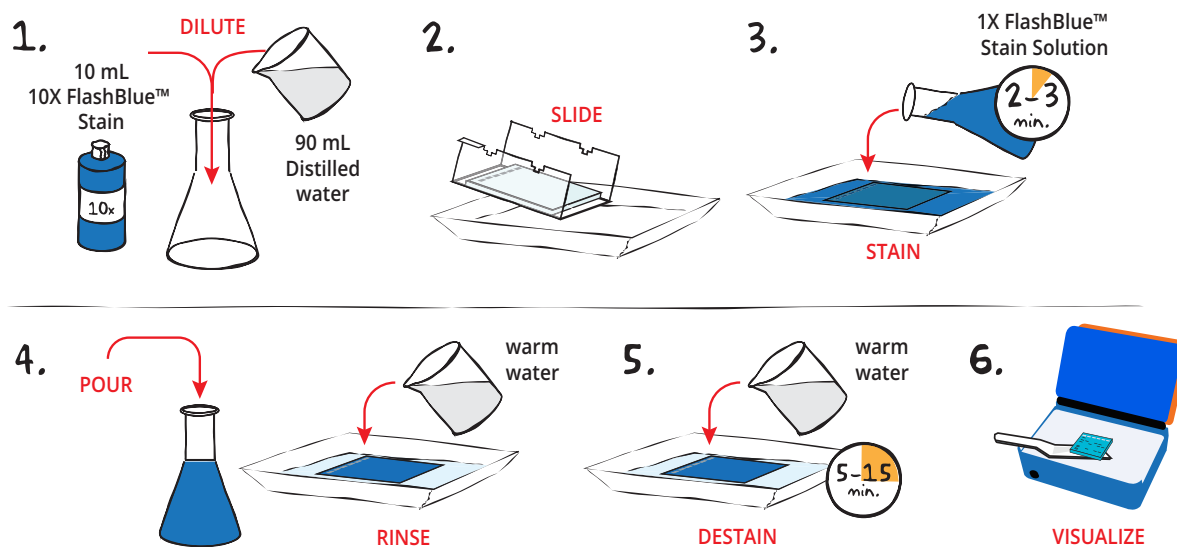

- DILUTE** 10 mL of 10X concentrated FlashBlue™ with 90 mL of distilled water in a flask. **MIX** well.
- REMOVE** the agarose gel and casting tray from the electrophoresis chamber. **SLIDE** the gel off the casting tray into a small, clean gel-staining tray.
- COVER** the gel with the 1X FlashBlue™ stain solution. **STAIN** the gel for 2-3 minutes. For best results, use an orbital shaker to gently agitate the gel while staining. **STAINING THE GEL FOR LONGER THAN 3 MINUTES WILL REQUIRE EXTRA DESTAINING TIME.**
- POUR** the 1X FlashBlue™ back into the flask (the stain can be reused). **COVER** the gel with warm water (40-45 °C). Gently **RINSE** the gel for 20-30 seconds. **POUR** off the water.
- COVER** the gel with clean, warm water (40-45 °C). **DESTAIN** for 5-15 minutes with gentle shaking (longer periods will yield better results). DNA bands will start to appear after 5 minutes of destaining. Changing the water frequently will accelerate destaining.
- Carefully **REMOVE** the gel from the destaining liquid. **VISUALIZE** results using a white light visualization system. DNA will appear as dark blue bands on a light blue background.



ALTERNATIVE FLASHBLUE™ STAINING PROTOCOL:

- DILUTE** 1 mL of 10X FlashBlue™ stain with 149 mL distilled water.
- COVER** the gel with diluted FlashBlue™ stain.
- SOAK** the gel in the staining liquid for at least three hours. For best results, stain gels overnight.
- Carefully **REMOVE** the gel from the staining liquid. **VISUALIZE** results using a white light visualization system. DNA will appear as dark blue bands on a light blue background.

Study Questions

1. How is sequenced DNA read on a DNA sequencing gel?
2. What is a dideoxynucleotide? How are these used in DNA sequencing?
3. If the concentration of a dideoxynucleotide is too low when mixed with the other four deoxynucleotides, how would that affect the sequencing results?
4. What would happen if the concentration of a dideoxynucleotide is too high?

Instructor's Guide

ADVANCE PREPARATION:

PREPARATION FOR:	WHAT TO DO:	WHEN?	TIME REQUIRED:
Module I: Agarose Gel Electrophoresis	Prepare QuickStrips™.	Up to one day before performing the experiment.	45 min.
	Prepare diluted electrophoresis buffer.		
	Prepare molten agarose and pour gels.		
Module II: Staining Agarose Gels Using FlashBlue™	Prepare staining components.	The class period or overnight after the class period.	10 min.

Technical Support

1.800.EDVOTEK

Mon. - Fri. 8 AM to 5:30 PM EST



Please Have the Following Info:

- Product Number & Description
- Lot Number on Box
- Order/Purchase Order #

1.800.EDVOTEK • info@edvotek.com • www.edvotek.com

www.edvotek.com

- Online Catalog
- Order Products
- Experiment Protocols
- Tech Support
- Resources!



NOTE:

Accurate pipetting is critical for maximizing successful experiment results. EDVOTEK Series 100 experiments are designed for students who have had previous experience with micropipetting techniques and agarose gel electrophoresis.

If students are unfamiliar with using micropipettes, we recommended performing [Cat. #S-44, Micropipetting Basics](#) or [Cat. #S-43, DNA DuraGel™](#) prior to conducting this experiment.

Pre-Lab Preparations: Module I

AGAROSE GEL ELECTROPHORESIS

This experiment requires 0.8% agarose gels. Enough reagents are provided to cast either eight 7 x 7 cm gels, eight 10 x 7 cm gels, or eight 14 x 7 cm gels. **For this experiment, 10 x 7 cm or 14 x 7 cm gels are highly recommended.** You can choose whether to prepare the gels in advance or have students prepare their own. Allow approximately 30 minutes for this procedure.

Individual Gel Preparation:

Each student group can be responsible for casting their own individual gel prior to conducting the experiment. See Module I in the Student's Experimental Procedure. Students will need 50x concentrated buffer, distilled water and agarose powder.

Batch Gel Preparation:

To save time, a larger quantity of agarose solution can be prepared for sharing by the class. Electrophoresis buffer can also be prepared in bulk. See Appendix B.

Preparing Gels in Advance:

Gels may be prepared ahead and stored for later use. Solidified gels can be stored under buffer in the refrigerator for up to 2 weeks.

Do not freeze gels at -20 °C as freezing will destroy the gels.

Gels that have been removed from their trays for storage should be "anchored" back to the tray with a few drops of molten agarose before being placed into the tray. This will prevent the gels from sliding around in the trays and the chambers.

SAMPLES FORMAT: PREPARING THE QUICKSTRIPS™

QuickStrip™ tubes consist of a microtiter block covered with a protective foil overlay. Each well contains pre-aliquoted sample.

Using sharp scissors, carefully divide the block of tubes into individual strips by cutting between the rows (see diagram at right). Take care not to damage the foil overlay while separating the samples.

Each lab group will receive one set of tubes, either rows A-D or rows E-H.

- A & E contain DNA Sequenced "A"
- B & F contain DNA Sequenced "C"
- C & G contain DNA Sequenced "G"
- D & H contain DNA Sequenced "T"

Before loading the gel, remind students to tap the tubes to collect the sample at the bottom of the tube. Puncture the foil overlay of the QuickStrip™ with a pipet tip to aspirate the sample. **Do not remove the foil as samples can spill.**

FOR MODULE I Each group will need:

- 50x concentrated buffer
- Distilled Water
- UltraSpec-Agarose™
- QuickStrip™ Samples

Quick Reference for EDVO-Kit #120

Size of gel casting tray	Groups per gel	Placement of comb	Wells required per group
7 x 7 cm	1 group	1st set of notches	4
10 x 7 cm	1 group	1st set of notches	4
14 x 7 cm	1 group	1st set of notches	4

NOTE:

This kit is compatible with [SYBR® Safe Stain](#) (Cat #608, not included). Instructions for preparing gels and visualizing results can be found in Appendix C.

Carefully cut between each set of tubes.
Then, between rows D and E.

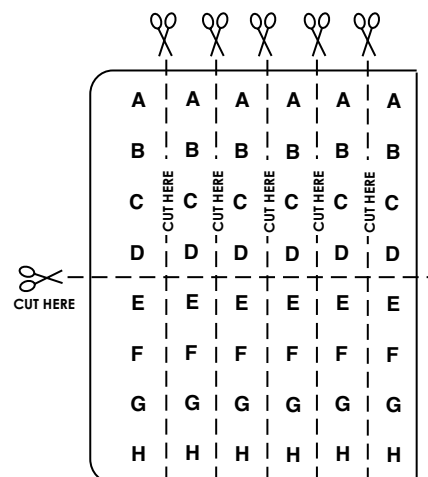

Pre-Lab Preparations: Module II

STAINING AGAROSE GELS USING FLASHBLUE™

FlashBlue™ stain is optimized to shorten the time required for both staining and destaining steps. Agarose gels can be stained with diluted FlashBlue™ for 5 minutes and destained for only 20 minutes. For the best results, leave the gel in liquid overnight. This will allow the stained gel to “equilibrate” in the destaining solution, resulting in dark blue DNA bands contrasting against a uniformly light blue background. A white light box ([Cat. #552](#)) is recommended for visualizing gels stained with FlashBlue™.

- Stained gels may be stored in destaining liquid for several weeks with refrigeration, although the bands may fade with time. If this happens, re-stain the gel.
- Destained gels can be discarded in solid waste disposal. Destaining solutions can be disposed of down the drain.

FOR MODULE II Each group will need:

- 10 mL 10X concentrated FlashBlue *OR* 100 mL 1x diluted FlashBlue
- Small plastic tray or weight boat
- Distilled or deionized water

PHOTODOCUMENTATION OF DNA (OPTIONAL)

Once gels are stained, you may wish to photograph your results. There are many different photodocumentation systems available, including digital systems that are interfaced directly with computers. Specific instructions will vary depending upon the type of photodocumentation system you are using.

Experiment Results and Analysis

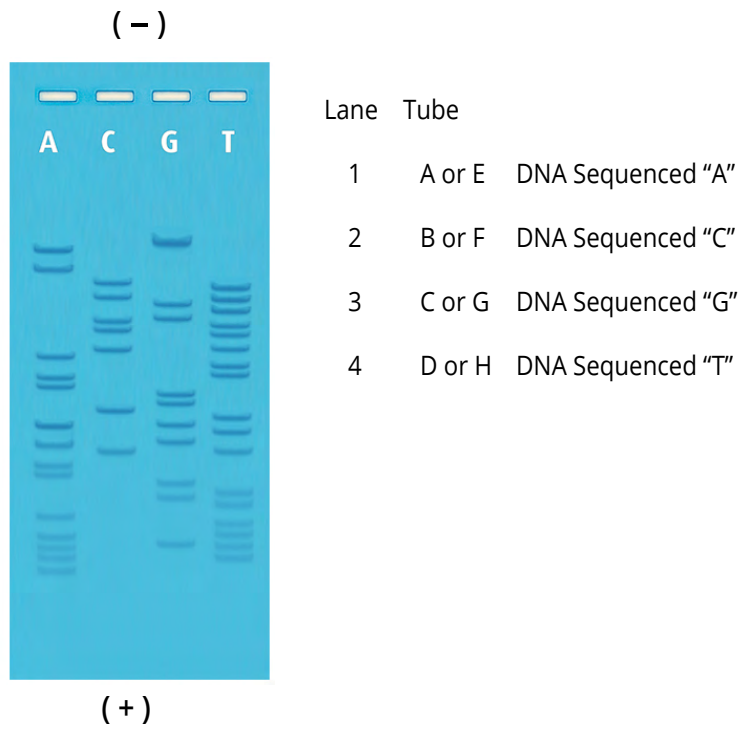

**Please refer to the kit
insert for the Answers to
Study Questions**

Appendices

- A EDVOTEK® Troubleshooting Guide
- B Bulk Preparation of Electrophoresis Buffer and Agarose Gels
- C Using SYBR® Safe Stain (OPTIONAL)

Safety Data Sheets can be found on our website: www.edvotek.com/safety-data-sheets

Technical Support

1.800.EDVOTEK

Mon. - Fri. 8 AM to 5:30 PM EST



Please Have the Following Info:

- Product Number & Description
- Lot Number on Box
- Order/Purchase Order #

1.800.EDVOTEK • info@edvotek.com • www.edvotek.com

www.edvotek.com

- Online Catalog
- Order Products
- Experiment Protocols
- Tech Support
- Resources!



Appendix A

EDVOTEK® Troubleshooting Guides

PROBLEM:	CAUSE:	ANSWER:
Bands are not visible on the gel.	The gel was not prepared properly.	Ensure that the electrophoresis buffer was correctly diluted.
	The gel was not stained properly.	Repeat staining protocol.
	Malfunctioning electrophoresis unit or power source.	Contact the manufacturer of the electrophoresis unit or power source.
After staining the gel, the DNA bands are faint.	The gel was not stained for a sufficient period of time.	Repeat staining protocol.
	The background of gel is too dark after staining with FlashBlue™.	Destain the gel for 5-10 minutes in distilled water.
DNA bands were not resolved.	Tracking dye should migrate at least 3 cm from the wells to ensure adequate separation.	Be sure to run the gel at least 3 cm before staining and visualizing the DNA (approximately 15-20 minutes at 150 V).
DNA bands fade when gels are kept at 4 °C.	DNA stained with FlashBlue™ may fade with time.	Re-stain the gel with FlashBlue™.
There is no separation between DNA bands, even though the tracking dye ran the appropriate distance.	The wrong percent gel was used for electrophoretic separation.	Be sure to prepare the correct percent agarose gel. For reference, the Ready-to-Load™ DNA samples should be analyzed using a 0.8% agarose gel.
There's not enough sample in my QuickStrip™.	The QuickStrip™ has dried out.	Add 40 µL water, gently pipet up and down to mix before loading.

Visit www.edvotek.com for additional troubleshooting suggestions.

Appendix B

Bulk Preparation of Electrophoresis Buffer and Agarose Gels

To save time, the electrophoresis buffer and agarose gel solution can be prepared in larger quantities for sharing by the class. Unused diluted buffer can be used at a later time and solidified agarose gel solution can be remelted.

Bulk Electrophoresis Buffer

Quantity (bulk) preparation for 3 liters of 1x electrophoresis buffer is outlined in Table D.

Table D Bulk Preparation of Electrophoresis Buffer			
50x Conc. Buffer	+	Distilled Water	Total Volume Required
60 mL		2,940 mL	3000 mL (3 L)

Batch Agarose Gels (0.8%)

For quantity (batch) preparation of 0.8% agarose gels, see Table E.

1. Use a 500 mL flask to prepare the diluted gel buffer.
2. Pour 4.0 grams of UltraSpec-Agarose™ into the prepared buffer. Swirl to disperse clumps.
3. With a marking pen, indicate the level of solution volume on the outside of the flask.
4. Heat the agarose solution as outlined previously for individual gel preparation. The heating time will require adjustment due to the larger total volume of gel buffer solution.
5. Cool the agarose solution to 60 °C with swirling to promote even dissipation of heat. If evaporation has occurred, add distilled water to bring the solution up to the original volume as marked on the flask in step 3.
6. Dispense the required volume of cooled agarose solution for casting each gel. Measure 30 mL for a 7 x 7 cm tray, 45 mL for a 10 x 7 cm tray, and 60 mL for a 14 x 7 cm tray. **For this experiment, 10 x 7 cm gels or 14 x 7 cm are highly recommended.**
7. Allow the gel to completely solidify. It will become firm and cool to the touch after approximately 20 minutes. Solidified gels can be stored under buffer in the refrigerator for up to 2 weeks. Do not freeze gels.

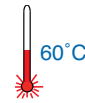

Table E Batch Prep of 0.8% UltraSpec-Agarose™					
Amt of Agarose	+	Concentrated Buffer (50X)	+	Distilled Water	Total Volume
4.0 g		10 mL		490 mL	500 mL

NOTE:

The UltraSpec-Agarose™ kit component is usually labeled with the amount it contains. Please read the label carefully. If the amount of agarose is not specified or if the bottle's plastic seal has been broken, weigh the agarose to ensure you are using the correct amount.

PROCEED to Loading and Running the Gel (page 10).

Appendix C

Using SYBR® Safe DNA Stain (OPTIONAL)

If desired, the DNA samples in this experiment can be visualized using [SYBR® Safe DNA stain \(Cat #608\)](#).

We recommend adding diluted SYBR® Safe stain to the liquid agarose gels while casting for easy, reproducible results. A blue light or UV transilluminator is needed for visualizing SYBR® gels. The TruBlu™ 2 ([Cat. #557](#)) is highly recommended.

PREPARING SYBR® SAFE STAIN

Instructors:

1. Prepare 1x Electrophoresis Buffer by combining 10 µL of 50X Concentrated Buffer with 490 µL of distilled water.
2. Add 20 µL of the SYBR® Safe to the tube of 1X buffer from Step 1 and mix by tapping the tube several times. The diluted SYBR® Safe Stain is now ready to be used during agarose gel preparation.

AGAROSE GEL PREPARATION

This experiment requires one 0.8% agarose gel for each student group. Instructors can choose whether to prepare the gels in advance (METHOD A) or have the students prepare their own (METHOD B). Allow approximately 30-40 minutes for this procedure.

Instructor Preparation (METHOD A):

For quantity (batch) preparation of agarose gels, see Table E.

1. Use a 500 mL flask to prepare the diluted gel buffer.
2. Pour 4.0 grams of UltraSpec-Agarose™ into the prepared buffer. Swirl to disperse clumps.
3. With a marking pen, indicate the level of solution volume on the outside of the flask.
4. Heat the agarose solution as outlined previously for individual gel preparation. The heating time will require adjustment due to the larger total volume of gel buffer solution.
5. Cool the agarose solution to 60 °C with swirling to promote even dissipation of heat. If evaporation has occurred, add distilled water to bring the solution up to the original volume as marked on the flask in step 3.
6. Add the entire tube of *diluted SYBR® Safe* stain to the cooled agarose and mix well.
7. Dispense the required volume of cooled agarose solution for casting each gel. Measure 30 mL for a 7 x 7 cm tray, 45 mL for a 10 x 7 cm tray, and 60 mL for a 14 x 7 cm tray. *For this experiment, 10 x 7 cm gels or 14 x 7 cm are highly recommended.*
8. Allow the gel to completely solidify. It will become firm and cool to the touch after approximately 20 minutes. Solidified gels can be stored in the refrigerator for up to 2 weeks. Place 1-2 mL of electrophoresis buffer in a sealable bag with the gels to prevent them from drying out. Excessive buffer will cause SYBR® Safe to diffuse out of the gels. Do not freeze gels.

PROCEED to Loading and Running the Gel (Steps 8-12 on page 10), followed by the VISUALIZATION procedures on page 23.

NO ADDITIONAL STAINING IS NECESSARY.

Table E				Batch Prep of 0.8% UltraSpec-Agarose™	
Amt of Agarose	+	Concentrated Buffer (50X)	+	Distilled Water	Total Volume
4.0 g		10 mL		490 mL	500 mL

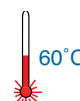

Appendix C

Using SYBR® Safe DNA Stain (OPTIONAL)

AGAROSE GEL PREPARATION, CONTINUED

Student Preparation (METHOD B):

For student preparation of agarose gels, see Table A.2.

1. **DILUTE** concentrated (50X) buffer with distilled water to create 1X buffer (see Table A.2).
2. **MIX** agarose powder with 1X buffer in a 250 mL flask (see Table A).
3. **DISSOLVE** agarose powder by boiling the solution. **MICROWAVE** the solution on high for 1 minute. Carefully **REMOVE** the flask from the microwave and **MIX** by swirling the flask. Continue to **HEAT** the solution in 15-second bursts until the agarose is completely dissolved (the solution should be clear like water).
4. **COOL** agarose to 60 °C with careful swirling to promote even dissipation of heat. 
5. While agarose is cooling, **SEAL** the ends of the gel-casting tray with the rubber end caps. **PLACE** the well template (comb) in the appropriate notch.
6. Before casting the gel, **ADD diluted SYBR® Safe** to the cooled agarose and swirl to mix (see Table A.2).
7. **POUR** the cooled agarose solution into the prepared gel-casting tray. The gel should thoroughly solidify within 20 minutes. The gel will stiffen and become less transparent as it solidifies.
8. **REMOVE** end caps and comb. Take particular care when removing the comb to prevent damage to the wells.

Size of Gel Casting tray	Concentrated Buffer (50x)	Distilled Water	Amt of Agarose	= TOTAL Volume	Diluted SYBR® (Step 6)
7 x 7 cm	0.6 mL	29.4 mL	0.24 g	30 mL	30 µL
10 x 7 cm*	0.9 mL	44.1 mL	0.36 g	45 mL	45 µL
14 x 7 cm	1.2 mL	58.8 mL	0.48 g	60 mL	60 µL

* Recommended gel volume for the EDGE™ Integrated Electrophoresis System.

PROCEED to Loading and Running the Gel (Steps 8-12 on page 10), followed by the VISUALIZATION procedures on page 23. **NO ADDITIONAL STAINING IS NECESSARY.**

Appendix C

Using SYBR® Safe DNA Stain (OPTIONAL)

VISUALIZING THE SYBR® GEL

A blue light or UV transilluminator is needed for visualizing SYBR® gels. The TruBlu™ 2 ([Cat. #557](#)) is highly recommended.

1.



2.

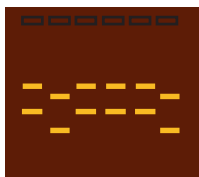

3.



1. **SLIDE** gel off the casting tray onto the viewing surface of the transilluminator.
2. Turn the unit **ON**. DNA should appear as bright green bands on a dark background. **PHOTOGRAPH** results.
3. Turn the unit **OFF**. **REMOVE** and **DISPOSE** of the gel. **CLEAN** the transilluminator surfaces with distilled water.



Be sure to wear UV goggles if using a UV transilluminator.