

QUICK-ELEC

MODULAR TEACHING SOLUTION



PERFECTLY SUITED TO ELECTRICAL ENGINEERING COURSES



Choice of frames



ref. MODULO-1

- Wheeled frame.
- Takes 20 modules (W-166mm x H-250mm)
- Dimensions: H-1610 x W-940 x D-500mm



ref. MODULO-2

- Wheeled frame.
- Takes 40 modules (W-166mm x H-250mm)
- Wood shelf 1500 x 350mm, with easy height adjustment
- Dimensions : H-2040 x W-1620 x D-650mm



ref. MODULO-3

- Frame for attaching to a table. (table not supplied)
- Takes 24 modules (W-166mm x H-250mm)
- Dimensions (without table): H-1100mm x W-1500 x D-500mm
- Depth adjustable using 2 slides attached to your table. Horizontal travel 250mm.

Common elements to the three frame models



Rear view



Front view

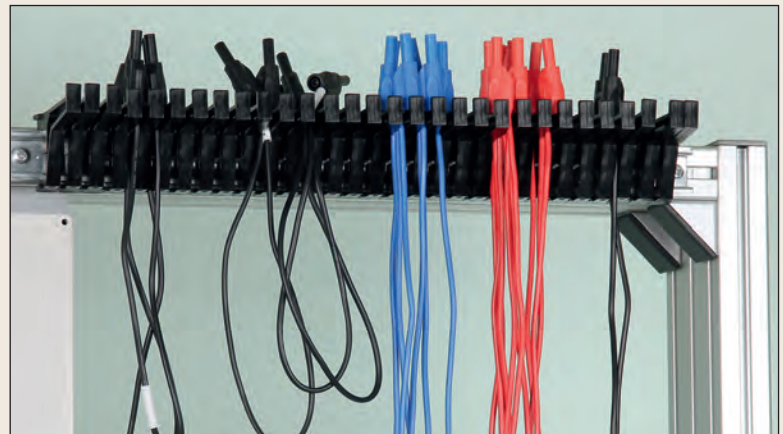

Power supply panel

Front:

- 1 16A thermal magnetic circuit breaker (option: 30mA residual current circuit breaker)
- 1 Emergency stop button
- 1 Pushbutton + ON indicator light
- 1 Mains output 230V+E on 4-mm safety terminals
- 2 Mains sockets 2P+E 230VAC

Rear:

- 10 Mains sockets 2P+E 230VAC

Rack for leads

- Length: 50cm.
- 30 fingers.
- The assembly can be moved longitudinally over the whole width of the frame.
- Positioned at the back of the frame.

Options compatible with MODULO frames



SCREEN/KEYBOARD SUPPORT

- Screen support arm
- 3 rotation points on 2 ball joints
- Supports one screen up to 12kg
- With shelf for keyboard and mouse

ref. **QUICK-ECRAN**

CAPACITIVE LOAD

- Adjustable from 0 to nominal power
- 6 switches
- Jumpers for coupling
- Power 0.5 or 2 or 4kVAR

ref. **QUICK-CH05 (0.5kVAR)**

ref. **QUICK-CH20 (2kVAR)**

ref. **QUICK-CH40 (4kVAR)**



The loads are designed to be easily removed from the frame.



CENTRAL UNIT SUPPORT

- Wire mesh 45x45mm
- Cabling space to rear
- Epoxy paint
- Dimensions: 400x400x195mm

ref. **QUICK-UC**

RESISTIVE LOAD

- Adjustable from 0 to nominal power
- 6 switches
- Jumpers for coupling
- Power 0.5 or 2 or 4kW

ref. **QUICK-RHP05 (0.5kW)**

ref. **QUICK-RHP20 (2kW)**

ref. **QUICK-RHP40 (4kW)**



WIRING GRID

Equipped with:

- 1 Omega rail 300mm
- 1 set of 20 terminals 6mm²
- 1 box equipped with 20 safety terminals Ø4mm
- Dimensions 500x350mm

The grid can be removed instantly without tools.

ref. **QUICK-GRIL**

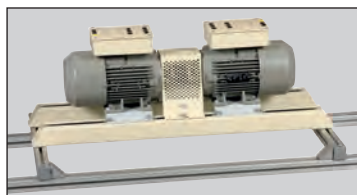

GUIDE RAILS

- Rails for rotating machines.
 - The distance between the rails can be adjusted from 70 to 380mm
 - Dimension: Length 900mm
- Supplied with sliding nuts.

ref. **QUICK-RGA**



STORAGE CABINET FOR MODULES

Takes at least 80 modules.

dim 900 x 1800 x 450mm

ref. **HB58 (supplied dismantled)**

Study of different wirings for lights



EDUCATIONAL OBJECTIVES

- Study of house wiring diagrams.
- Study and operation of a single lighting circuit.
- Study and operation of a double lighting circuit.
- Study and operation of a two-way circuit.
- Study and operation of a remote control switch circuit
- Study and operation of a timer circuit.
- Study and operation of a dusk switch circuit.
- Study and operation of an energy meter.

TEACHING RESOURCES STUDENT & TEACHER

Proposed Practical Works

- Creation of house lights wiring diagrams.
- Creation of different light wiring such as single, double, two-way, timer, remote control, dusk switch.
- Creation of energy meter wiring.
- Creation of reading of light power consumption.

ref. QUICK-A

QUICK-A is a set of modules (H-250mm) for studying the different types of wiring of lights. The modules are cabled using safety leads Ø4mm.

Comprises

- 1 Module – Two pushbuttons
- 1 Module – Two-way switch
- 1 Module – Two single lighting switches
- 1 Module – Two double lighting switches
- 1 Module – Single phase energy meter 63A
- 1 Module – Circuit-breaker 1P+E 16A
- 1 Module – Residual current circuit-breaker 30mA
- 1 Module – Timer, coil 230VAC-50Hz
- 1 Module – Remote control switch, coil 230VAC-50Hz
- 1 Module – Dusk switch + photocell
- 1 Module – Analogue ammeter 2.5A and Analogue voltmeter 250VAC
- 4 Modules – Bulkhead lights 230VAC-40W
- 1 set of safety leads for carrying out the different practical works.

Study of access control with encodable swipe cards and digicodes



QUICK-B is a set of modules (H250mm) for studying the access control of a building with encodable swipe cards and keypads. Cabling of the modules using 4mm Ø safety leads.

ref. QUICK-B

EDUCATIONAL OBJECTIVES

- Study the wiring diagrams for room access control with keypad and swipe cards.
- Study and operation of a swipe card programming.
- Study and operation of an electromagnetic lock controlled by a keypad.
- Study and operation of 2 electromagnetic locks controlled by swipe cards or pushbuttons.
- Study and operation of a room access schedule according to the time, day of the week and type of authorization.

TEACHING RESOURCES STUDENT & TEACHER

Proposed Practical Works

- Creation of the wiring diagrams.
- Creation, using software, of the programming for encodable swipe cards according to access authorizations, times and days of the week.
- Creation of the complete wiring.

Comprises

- 1 Power supply module 24V DC
- 1 Power supply module VIGIK 8-module output Bus 27V DC.
- 1 VIGIK central module for swipe card control for 2 access points.
- 1 Keypad module for setting with more than 100 combinations.
- 1 2-reader module for swipe cards.
- 1 Electromagnetic suction cup module 24V DC.
- 2 Electromagnetic door lock modules 24V DC.
- 1 2-pushbutton module.
- 6 Encodable swipe cards.
- 1 Swipe card encoder with access control software. USB output to PC.
- Set of 4mm connection leads.

Study of wirings for starting asynchronous motors

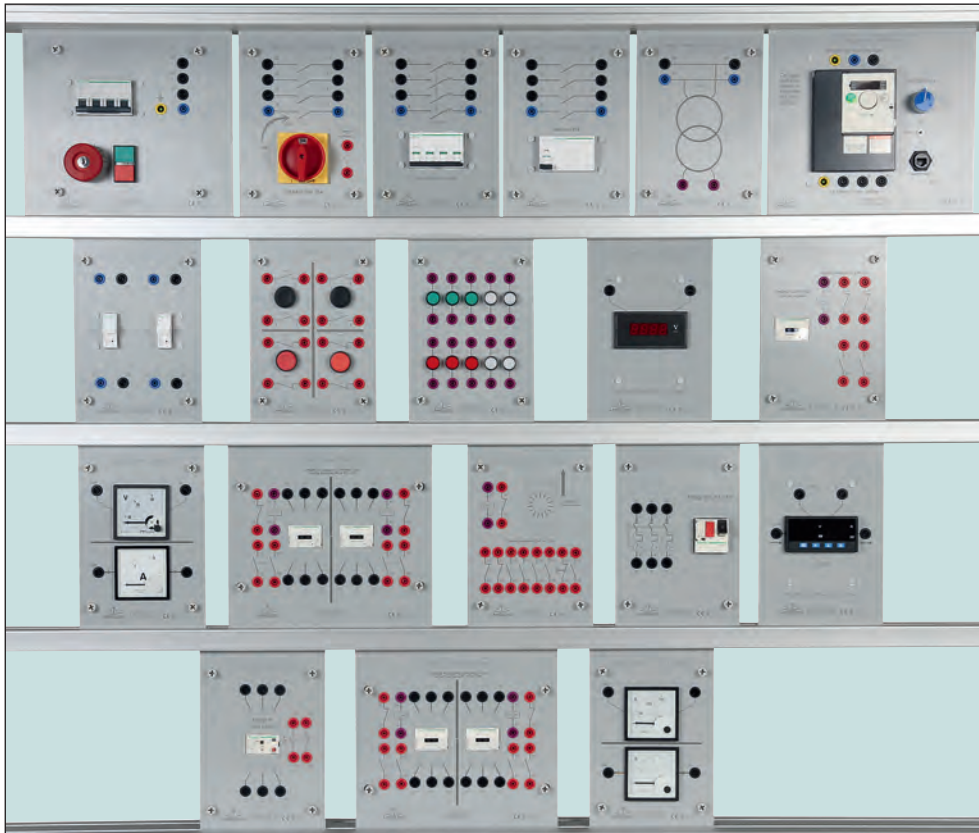

QUICK-C is a set of modules for studying the different types of wiring for starting asynchronous motors. The modules are cabled using safety leads Ø4mm. Compatible with asynchronous motors 400/690V 1500W max.

ref. QUICK-C

EDUCATIONAL OBJECTIVES

- Study of wiring diagrams for starting asynchronous motors.
- Study and operation of direct start-up.
- Study and operation of direct start-up with reversal of the direction of rotation.
- Study and operation of star/delta start-up.
- Configuration of a speed controller with software.
- Study and operation of start-up with speed controller.
- Using a digital wattmeter, ammeter and voltmeter.

TEACHING RESOURCES STUDENT & TEACHER

Proposed Practical Works

- Creation of the wiring diagrams of different types of motor start-up.
- Creation of the different wirings of motor start-ups such as direct, direct with reversal of the direction of rotation, star/delta, with speed controller.
- Configuration of the speed controller using the SOMOVE software from Schneider
- Reading of the currents and voltages at the terminals of the asynchronous motor.
- Calculation of the absorbed power.

Comprises

- 1 Module – Distribution of three-phase voltage + Neutral 400V-50Hz
- 1 Module – Emergency stop
- 1 Module – 2 two-pole cut-out devices
- 1 Module – Four-pole magneto-thermal circuit-breaker 4A D-curve
- 1 Module – Residual current four-pole switch 30mA
- 1 Module – Three-pole thermal magnetic circuit-breaker, motor support
- 1 Module – Four-pole isolating switch
- 1 Module – Transformer 230V/24VAC-50Hz 120VA
- 1 Module – Four pushbuttons
- 1 Module – 10 indicator lights 24VAC-50Hz
- 1 Module – Reversing contactor 24VAC-50Hz with 2NO+2NC
- 2 Modules – Contactors 24VAC-50Hz with 2NO+2NC
- 1 Module – Timed contactor 24VAC-50Hz
- 1 Module – Thermal relay
- 2 Modules – Analogue voltmeter (400V) and ammeter (10A) displays.
- 2 Modules – Digital wattmeter displays.
- 1 Module – Speed controller 1.5kW power supply and 3-phase 400V output.
- 1 set of safety leads for carrying out the different practical works.

FAN OPTION

QUICK-C can be completed by a fan.

- 300W 400/690V three-phase fan
- Rated speed 1500 rpm
- Power supply through 4mm dual chamber safety terminals

ref. KT-1M

Protection grid removed for photo purposes only



Study of an asynchronous motor 1500W with powder brake

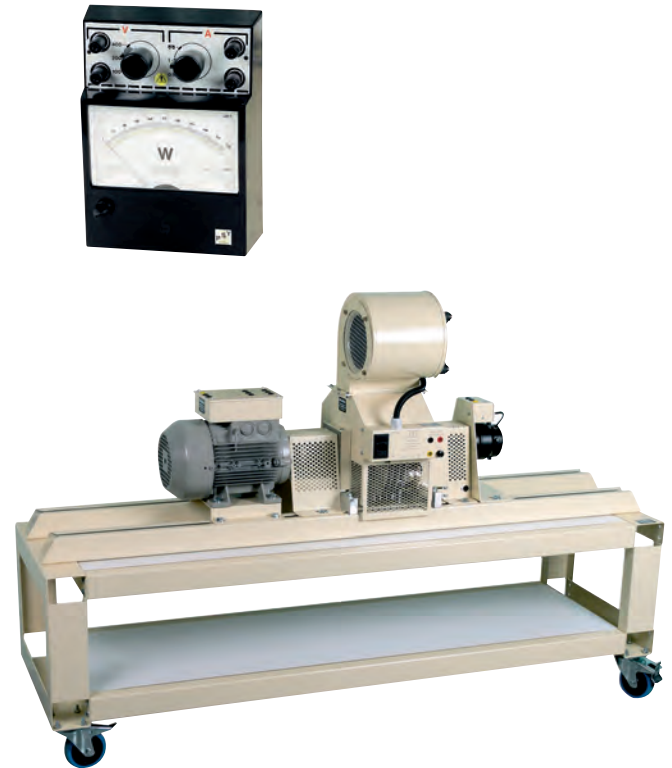

Sets of modules (H-250mm) and rotating machinery for studying an asynchronous motor 1500W coupled with a powder brake with torque sensor and tachometer generator.

ref. QUICK-F (version monophasée)

Requires connection to a mains single-phase electricity supply 230V AC

ref. QUICK-FT (version triphasée)

Requires connection to a mains 3-phase electricity supply 3 x 400V AC + Neutral

Comprises

- 1 Power supply module with RC circuit-breaker and emergency stop button.
- 1 Speed controller module 1500W (single-phase or 3-phase according to version) with SoMove programming software.
- 1 Module with magneto-thermal circuit-breaker for motor support.
- 1 Wattmeter switch module.
- 1 Power supply module 0-20V DC for powder brake supply.
- 1 Voltage digital display module.
- 1 Current digital display module.
- 1 Motor torque digital display module.
- 1 Rotation speed digital display module.
- 1 Analogue wattmeter RMS AC+DC.
- 1 Complete motor set on wheeled cart equipped with three-phase asynchronous motor 230/400V - 1500W, powder brake, rotary torque sensor, and tachometer generator.
- 1 set of safety leads for carrying out the different practical works. A version without motor set can be offered on request.

EDUCATIONAL OBJECTIVES

- Study the wiring diagram between a speed controller and an asynchronous motor.
- Study the configuration of a speed controller using SoMove software.
- Study the no-load behaviour of a three-phase asynchronous motor 1500W.
- Study the with-load behaviour of a three-phase asynchronous motor 1500W.
- Read and plot the electrical and mechanical characteristics of an asynchronous motor.

TEACHING RESOURCES STUDENT & TEACHER

Proposed Practical Works

- Creation of the wiring diagram of a speed controller and an asynchronous motor.
- Creation of the configuration of a speed controller using SoMove software.
- Creation of the no-load and with-load tests of the asynchronous motor.
- Calculations & plots of the electrical and mechanical characteristics of the motor bench.

Study of a single-phase transformer 230V-140VA



QUICK-G is a set of modules (H-250mm) for studying a compensated single-phase transformer 230V with three secondary windings.

ref. QUICK-G

EDUCATIONAL OBJECTIVES

- Study a single-phase transformer with no load, in short-circuit and loaded.
- Measurement of the different electrical values at the primary and secondary windings.
- Calculation of the powers, efficiency, transformation ratio, and losses of the transformer.

TEACHING RESOURCES STUDENT & TEACHER

Proposed Practical Works

- Creation of the wiring diagram with measuring devices.
- Study of the use of the compensation winding at the primary.
- Readings of the electrical values of the transformer with no-load.
- Readings of the electrical values of the transformer with load.
- Calculations of the electrical characteristics, power and the transformation ratio.
- Plots of the curves of electrical power and efficiency.

Comprises

- 1 Variable autotransformer module 0-250V AC - 5A.
- 1 Single-phase transformer module 140VA.
Primary winding 230V, 1 secondary winding 15V/3.6A and 2 fuse-protected separate secondary windings 12V/3.6A.
- 3 Voltage digital display modules.
- 3 Current digital display modules.
- 3 Power digital display modules.
- 1 Variable rheostats module 0-22 ohms.
- 1 Variable rheostats module 0-3.3 ohms.
- 1 set of safety leads for carrying out the different practical works.
Mains power supply 230V - 50/60Hz. 3-metre lead with plug 2P+E.

Study of the role of the earth and a residual current circuit-breaker



QUICK-H is a set of modules (H250mm) for studying the role of the earth and an RC circuit-breaker. The synoptic diagrams on the modules show the path of electrical energy from a transformer substation and a house. Resistive dipoles, for insertion in the modules, allow students to simulate two earth resistance values and two fault resistance values. To prevent any risk of electrocution to the student, the modules operate at extra-low voltage using an isolating transformer to standard NFC61558.

ref. QUICK-H

EDUCATIONAL OBJECTIVES

- Make students aware of electrocution risks in the event of indirect contact.
- Make students aware of risks related to the quality of the earth.
- Explain the role of the RC circuit-breaker 30mA in a domestic installation.

TEACHING RESOURCES STUDENT & TEACHER

Proposed Practical Works

- Operation of a magneto-thermal circuit-breaker: rating, breaking capacity, tripping curve, and symbols.
- Operation of an RC circuit-breaker: rating, tripping time, and symbols.
- Physiological effects of the current: risk areas, risk according to the current, and dangerous voltages.
- Maximum resistance of the earth.

Comprises

- 1 Transformer module 230V AC, 24V AC. A printed diagram shows the public network, with its medium/low voltage transformer substation, and the neutral to earth connection in this substation.
- 2 Modules of transmission lines from the transformer substation to a domestic installation.
- 2 Modules with the RC circuit-breaker 30mA, and a washing machine simulation.
- 1 Module with a printed diagram of a person, equipped with an LED on the heart. If a dangerous leakage current flows, the LED comes on.
- 1 Dipole support module. Two earth resistances (100 and 5 ohms), two fault resistances (10 and 2K ohms) and four blanks so you can use your own resistance values.
- 1 set of safety leads for carrying out the different practical works. Mains power supply 230V - 50/60Hz. 3-metre lead with plug 2P+E.



Study of the behaviour of a machine in hypo and hypersynchrony



QUICK-I presented on the MODULO-2 frame

EDUCATIONAL OBJECTIVES

- Study the hyposynchronous and hypersynchronous operations of an asynchronous motor.
- Study the effect of a battery of capacitors on the power factor value.
- Study the synchronisation with the national grid.
- Study energy use at an isolated site.
- Calculate the efficiencies of an energy production system.
- Use a clamp ammeter.

TEACHING RESOURCES STUDENT & TEACHER

Proposed Practical Works

- Procedure of synchronization with the national grid.
- Hyposynchronous and hypersynchronous measurement.
- Reading power factor using a battery of capacitors and consequences.
- Plot of the electrical characteristics of the energy production system.
- Calculation of the overall efficiency.
- Study of the operation at an isolated site.

ref. QUICK-I

An asynchronous motor can convert mechanical energy into electrical energy. To perform this conversion, it has to be driven above the synchronous speed. QUICK-I is a set of modules of measurement (H-250mm) of switching and 2 asynchronous motors mounted on the same axis of rotation for studying hypersynchrony. The speed controller module drives the first motor above its synchronous speed so that the second becomes a three-phase generator.

A central zero wattmeter module indicates the direction of the electrical energy consumed or fed in the case of feeding into the grid.

A central 0 phase-meter module demonstrates the change of power factor according to the addition of capacitors or speed variation.

Comprises

- 1 Single-phase power supply module 230V AC with RC circuit-breaker and emergency stop button.
- 1 Speed controller module 1500W. Single-phase power supply 230V AC, motor supply output 3 x 230V AC. Adjustment of the rotation frequency by potentiometer on the front.
- 1 Three-pole cut-out module.
- 1 Current digital display module.
- 1 Voltage digital display module.
- 1 Module with central zero analogue display of the power.
- 1 Module with central 0 analogue display of power factor.
- 1 Start/Stop switch module for synchronizing with the electricity grid 3x230/400V.
- 1 Set of rotating machinery: 2 asynchronous motors 1500W, 3x 230/400V.
- 1 Resistive load 2000W.
- 1 Capacitive load 2000 kVAR.
- 1 set of safety leads for carrying out the different practical works. Mains power supply 230V - 50/60Hz. 3-metre lead with plug 2P+E.

The set can be supplied without the motor set, without capacitive or resistive load, please ask for details.

Study of the synchronization of an alternator with the electrical grid

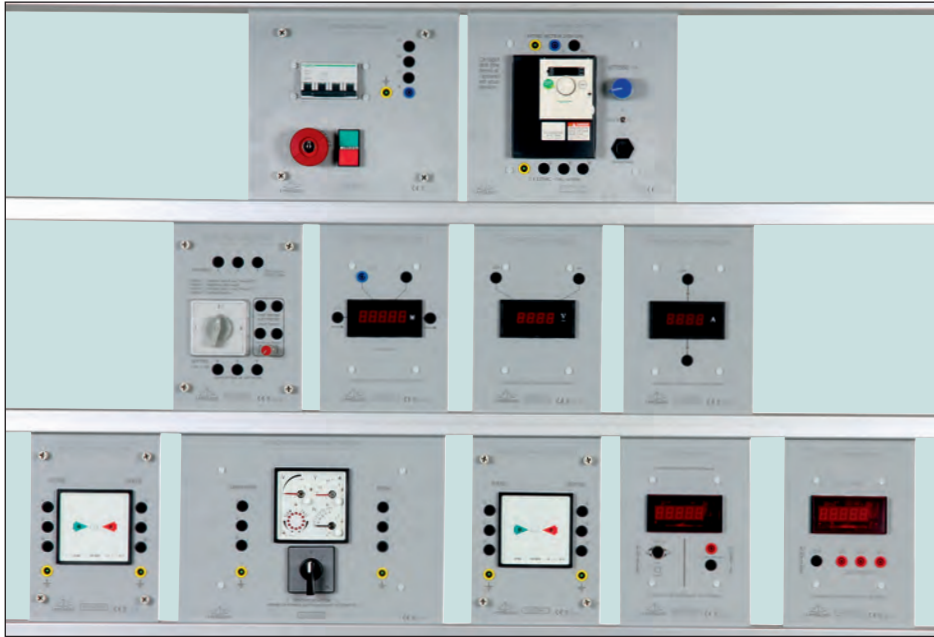

ref. QUICK-J

QUICK-J is a set of modules (H-250mm) and rotating machinery for studying the synchronization of an alternator 1500W with the electricity grid 3 x 400V.

EDUCATIONAL OBJECTIVES

- Understand the operation of a synchronous alternator.
- Understand the rules of synchronization with the electricity grid.
- Use a synchronoscope.
- Study the wiring diagram between a speed controller and an asynchronous motor.
- Creation of the configuration of a speed controller with software.
- Study the no-load and with-load behaviour of a 3-phase asynchronous motor 1500W.
- Study the no-load and with-load behaviour of an alternator.
- Read and plot the electrical and mechanical characteristics of the motor bench.

TEACHING RESOURCES STUDENT & TEACHER

Proposed Practical Works

- Creation of the wiring diagram of a speed controller and the asynchronous motor.
- Configuration of the speed controller with software.
- Creation of the wiring of the alternator and the synchronoscope.
- Creation of the no-load and with-load tests of the asynchronous motor.
- Creation of the no-load and with-load tests of the alternator.
- Calculations and plots of the electrical and mechanical characteristics of the motor bench.

Comprises

- 1 Single-phase power supply module with RC circuit-breaker and emergency stop button.
- 1 Single-phase speed controller module 230V AC – 3x230V AC, 1500W. Adjustment of the rotation speed setting by potentiometer on the front.
- 1 Voltage digital display module.
- 1 Current digital display module.
- 1 Wattmeter switch module.
- 1 Power digital display module.
- 1 Motor torque digital display module.
- 1 Rotation speed digital display module.
- 1 Indicator module of phase order on the alternator side.
- 1 Indicator module of phase order on the electricity grid side.
- 1 Switching module with display of the matching of the voltages, speed of synchronism, frequency of the alternator, and output voltage of the alternator.
- 1 Machinery set on wheeled cart comprised of:
 - 1 Asynchronous motor 1500W - 3x 230V/3x400V
 - 1 Brushless rotary dynamic torque sensor
 - 1 Synchronous machine 1500W - 3x230V/3x400V
 - 1 Tachometer generator 10V/1000 revs
- 1 Analogue wattmeter RMS AC+DC.
- 1 Variable power supply 0-240V AC/DC for supplying the rotary field of the alternator.
- 1 set of safety leads for carrying out the different practical works. Mains power supply 230V - 50/60Hz. 3-metre lead with plug 2P+E.

The set can be supplied without the motor set, please ask for details.

study of temperature regulation by proportional integral derivative (PID)

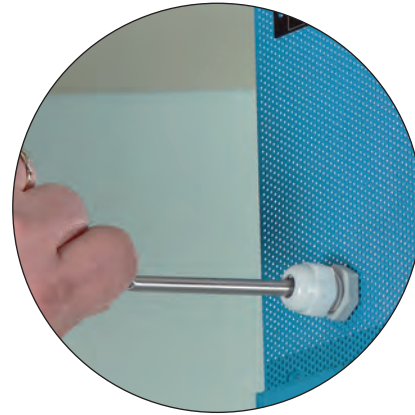

QUICK-K is a set of modules (H-250mm) for studying temperature regulation by PID.

ref. QUICK-K

EDUCATIONAL OBJECTIVES

- Learn about and wire a system of temperature regulation by PID.
- Study, configure, and control a PID regulator.
- Study an analogue signal 4-20mA.
- Study a PT100 temperature sensor signal.
- Use a dimmer 230V, 4-20mA.

TEACHING RESOURCES STUDENT & TEACHER

Proposed Practical Works

- Creation of the complete wiring diagram of the temperature regulation system.
- Configuration of the PID regulator for an analogue signal 4-20mA.
- Temperature regulation according to several set points.

Comprises

- 1 DC power supply module 230V AC, 24V DC - 3A.
- 1 PID temperature regulator module. Self-adjusting and manual. 4-digit display for set point, input and output 4-20mA. Binary alarm output.
- 1 PT100 temperature sensor module. Three wires.
- 1 PT100 signal converter module, 4-20mA.
- 1 Indicator light module 230V AC
- 1 Single-phase power dimmer module. Variation of the thyristor conduction angle according to the control current 4-20mA.
- 1 Heating unit module equipped with a 75W lamp powered at 230VAC. Thanks to two supports, the temperature sensor can be put into the unit.
- 1 set of safety leads for carrying out the different practical works. Mains power supply 230V - 50/60Hz. 3-metre lead with plug 2P+E.

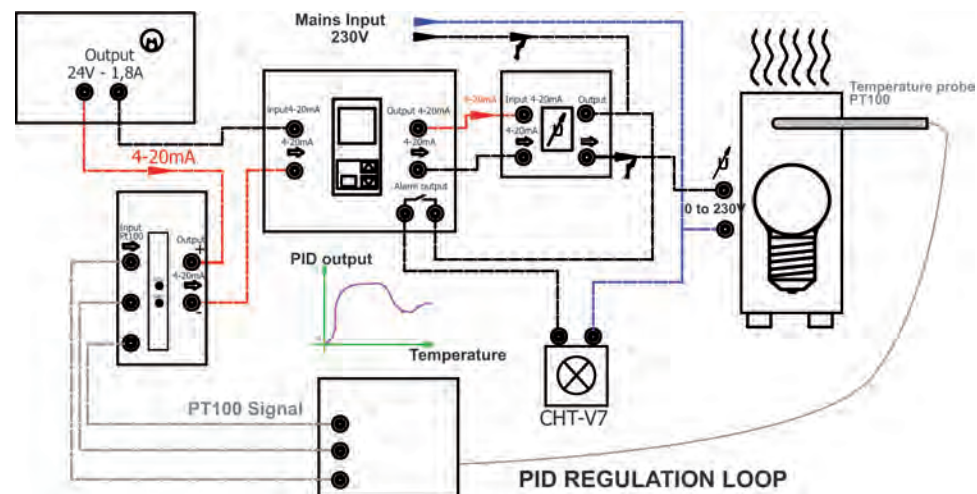

Study of power factor rectification



QUICK-L is a set of modules for studying the power factor rectification of an electrical installation.
The modules are cabled using safety leads Ø4mm.
Compatible load 230V-5A Max.

ref. QUICK-L

EDUCATIONAL OBJECTIVES

- Study of the power factor.
- Study of the powers.
- Demonstrate the advantage of rectifying power factor on the kWh cost

TEACHING RESOURCES STUDENT & TEACHER

Proposed Practical Works

- Study of an industrial lighting installation using a fluorescent tube: Readings of current, power and voltage in each energy transmission line.
- Creation of the Fresnel diagram using active and reactive powers.
- Study of pure inductance in order to determine the capacitor battery to be installed.
- Study of resonance, max/min current.

Comprises

- 1 Module – Distribution of single-phase voltage 230VAC-50Hz
- 3 Modules – Digital ammeters 5A
- 1 Module – Digital voltmeter single-phase 230VAC
- 3 Modules – Digital multifunction displays 230VAC-5A. Displays of P/U/I/Power factor.
- 3 Modules – Reactive power 230VAC-5A.
- 1 Module for load connection
- 1 Module – battery of 10 capacitors 0.1 to 41µF with jumpers.
- 1 Module – safety inductance, variable from 0.1 to 1.4H - 2A
- 1 Module – Fluorescent tube 230VAC-18W
- 1 set of safety leads for carrying out the different practical works.

Study of the feeding of photovoltaic energy to the electrical grid



QUICK-M is a set of photovoltaic modules (H-250mm) and solar panels for studying a solar installation with energy feeding to the 230V AC grid.

ref. QUICK-M

EDUCATIONAL OBJECTIVES

- Learn about a photovoltaic installation with energy feeding to the grid.
- Study the types of energy feeding to the grid, e.g. total or partial.
- Learn about and understand the photovoltaic elements present.
- Create the wiring of a photovoltaic installation.
- Take the electrical measurements of the different values.
- Study the efficiency and incidences related to the positioning of the solar panels.
- Study the use of a grid inverter and energy meter.

TEACHING RESOURCES STUDENT & TEACHER

Proposed Practical Works

- Creation of the complete wiring diagram for feeding all the energy produced by the panels.
- Creation of the complete wiring diagram for feeding the non-consumed energy produced by the panels.
- Take the measurements of voltage, current and power of the solar panels.
- Take the measurements of the fed voltage, current and power.
- Calculation of the efficiency of the installation.

Comprises

- 1 Coupler module of photovoltaic terminals to 4mm terminals.
- 1 Surge arrester module.
- 1 Circuit switching module.
- 1 Double fuse holder module 10x38 gPV.
- 3 Single-phase energy meters modules 63A. Reset key. Resolution 0.1kW
- 1 Grid inverter module 500W. Automatic synchronization with the grid 230V. Input voltage from 65 to 130V DC. Thermal protection integral to the box.
- 1 Module of photovoltaic two-pole circuit-breaker with fault current VDE0126.
- 1 Grid synchronization switch module.
- 1 Module with outlet 2P+E, 4mm terminals.
- 1 Analogue voltmeter/ammeter module.
- 1 Digital voltmeter module.
- 1 Digital ammeter module.
- 2 Solar panels 200Wc on frame that tilts from 5° to 70°.
- 1 Photovoltaic cable, 30 metres.
- 1 set of safety leads for carrying out the different practical works.

The set can be supplied without the two solar panels, please ask for details.

RECOMMENDED OPTION FOR INDOOR OPERATION

ARTIFICIAL SOLAR SOURCE Qty 2

This source for getting around the loss of sunlight by illuminating the solar panel with an artificial light whose spectrum is close to sunlight.

While not having as much luminosity as unclouded sunlight, it illuminates with sufficient intensity for the panel to generate 1/3 of its peak power Wc (corresponding to sunlight at 1kW/m²). Ask for details.



Study of photovoltaic energy on an isolated site



QUICK-N is a set of photovoltaic modules (H-250mm) and solar panels for studying a solar installation on an isolated site.

ref. QUICK-N

EDUCATIONAL OBJECTIVES

- Learn about a photovoltaic installation on an isolated site.
- Learn about and understand the photovoltaic elements present.
- Creating a Photovoltaic installation.
- Taking the electrical measurements of the different values.
- Study the efficiency and incidences related to the positioning of the panels.
- Study the energy system (production, storage, charge, discharge).
- Study the use of a solar charge regulator for batteries.

TEACHING RESOURCES STUDENT & TEACHER

Proposed Practical Works

- Creation of the complete wiring diagram.
- Creation of the configuration of the charge regulator for batteries.
- Take the measurements of voltage, current and power of the solar panels.
- Take the measurements of voltage, current and power at output 24V DC.
- Calculation of the efficiency of the installation.
- Calculation of the charge/discharge time of the battery.

Comprises

- 1 Coupler module of photovoltaic terminals to 4mm terminals.
- 1 Surge arrester module.
- 1 Circuit switching module.
- 3 Double fuse holder modules 10x38 gPV.
- 1 Solar charge regulator module 24V DC - 20A
- 1 Voltage converter module 350VA - 24V DC - 230V AC on outlet 2P+E.
- 2 Voltmeter/ammeter analogue display modules.
- 1 Two batteries module 12V - 12Ah.
- 2 Solar panels 200Wc on frame that tilts from 5° to 70°.
- 1 Photovoltaic cable, 30 metres.
- 1 set of safety leads for carrying out the different practical works.

The set can be supplied without the two solar panels, please ask for details.

RECOMMENDED OPTION FOR INDOOR OPERATION

ARTIFICIAL SOLAR SOURCE Qty 2

This source for getting around the loss of sunlight by illuminating the solar panel with an artificial light whose spectrum is close to sunlight. While not having as much luminosity as unclouded sunlight, it illuminates with sufficient intensity for the panel to generate 1/3 of its peak power Wc (corresponding to sunlight at 1kW/m²). Ask for details.



Study system for the KNX bus



QUICK-KNX presented on MODULO-1 frame

EDUCATIONAL OBJECTIVES

- Studying KNX communication media
- Studying the principle of a home control installation with KNX devices
- Configuration of KNX devices
- Creating the wiring of KNX devices
- Creating home control scenarios

TEACHING RESOURCES STUDENT & TEACHER

Proposed Practical Works

- Creation of the complete wiring diagram
- Study the creation of KNX wiring and programming for the functions of lighting control, shutter and opening control using pushbuttons
- Creation of home control scenarios like using a single key to switch off the lights, lower the blinds and open the garage door and the gate
- Combine several different brands makes with the same KNX standard

Réf. QUICK-KNX

The KNX bus offers a standard of compatibility and interoperability that is unique and global in the home control sector.

With "KNX PARTNER" certified manufacture, the DOMO-KNX model enables the study and putting into service of multibrand KNX products, SCHNEIDER® and HAGER® (other on request). The KNX devices are prepared in plastic housings with the front engraved and equipped with Ø4mm terminals. The wiring of the Bus and the power are then created using safety leads. We selected the most commonly used KNX modules in the "intelligent home" domain. These modules are easy to install on the aluminium wheeled frame.

The KNX devices are configured using the ETS Lite tool (20 participants max.) supplied with the model.

Comprises

- 1 30V power supply module for the bus
- 1 USB interface module for programming from a PC
- 2 4-key pushbutton modules with indicator lights (1 per brand)
- 1 2-key pushbutton module with indicator lights
- 1 universal pushbutton interface module
- 1 Presence detector module
- 1 4-output switch actuator module
- 1 2-outputs switch actuator module
- 1 2-outputs control actuator module
- 1 1-outputs control actuator module
- 1 2-outputs roller blind actuator module
- 1 Module with printing and signalling for two roller blinds
- 1 Module with printing and signalling for opening / closing gate and garage
- 4 Modules for bulkhead lights 60W – 230VAC

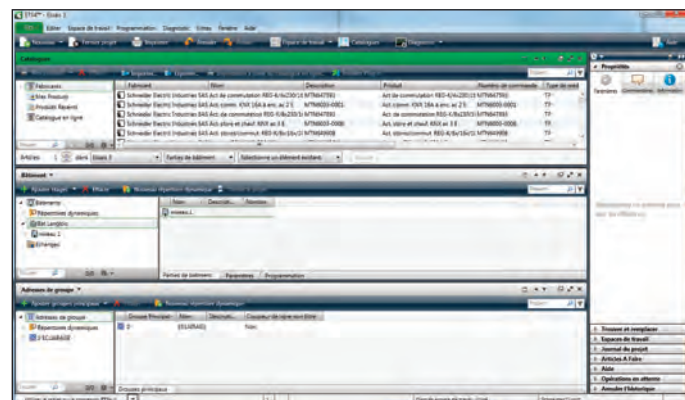

ETS Lite programming software

Modular power supply system AC + DC

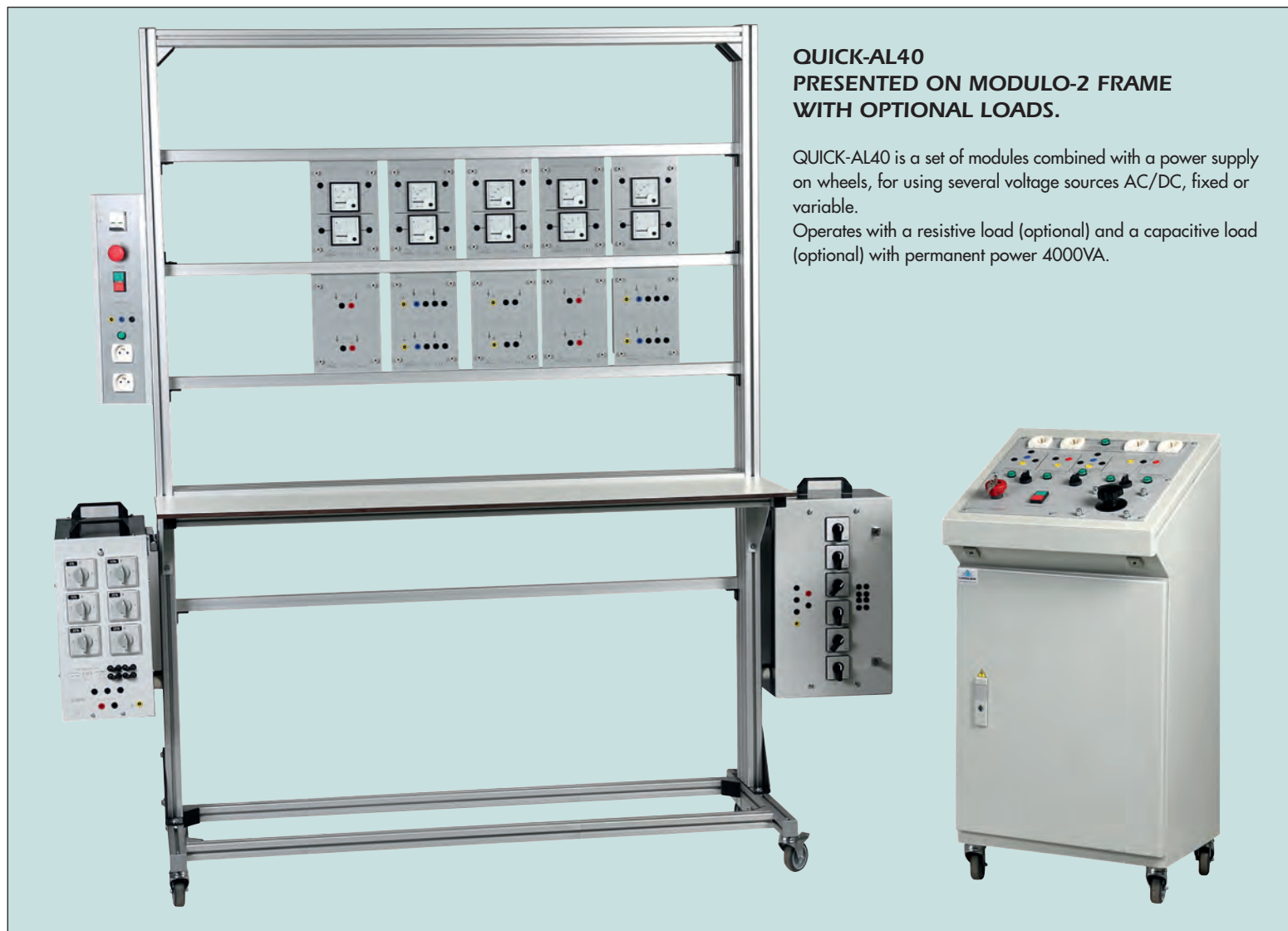

QUICK-AL40 PRESENTED ON MODULO-2 FRAME WITH OPTIONAL LOADS.

QUICK-AL40 is a set of modules combined with a power supply on wheels, for using several voltage sources AC/DC, fixed or variable.

Operates with a resistive load (optional) and a capacitive load (optional) with permanent power 4000VA.

ref. QUICK-AL40

Comprises

- 1 wheeled cabinet (see description page 19)
- 2 Analogue voltmeter 450V and ammeter 20A modules.
- 1 Analogue voltmeter 450V and ammeter 10A module
- 2 Analogue voltmeter 300V and ammeter 2.5A modules.
- 1 Interface module, 4mm safety terminals for MAIN THREE-PHASE output.
- 1 Interface module, 4mm safety terminals for MAIN DC output.
- 1 Interface module, 4mm safety terminals for AUXILIARY SINGLE-PHASE output.
- 1 Interface module, 4mm safety terminals for AUXILIARY DC output.
- 1 Interface module, 4mm safety terminals for MAINS THREE-PHASE output.
- 1 set of safety leads for making connections.

Three-phase power supply 3 x 400V + N. Mains lead, 3 metres.



Description of the cabinet

Wheeled cabinet equipped with magneto-thermal and RC circuit-breakers for safely distributing the different sources of power supply.

- **Emergency stop and main start/stop button**
- **Main three-phase: 0-450V AC, 8A**
 Can be varied by autotransformer on the side of the cabinet and protected against overloads and short-circuits. The proposed voltage is 0-450V between phases.
 A thermal magnetic circuit-breaker protects this output. A contactor with control button ensures Start/Stop switching, provided that the autotransformer is at 0 voltage.
 An indicator signals powering up.
- **Main DC voltage: 0-270V DC, 16A**
 0-270V variable, by autotransformer, with isolating transformer, to standard NFC 61558; the set is protected against overloads and short-circuits.
 Rectification is generously oversized (ripple factor 4%).
 Thermal magnetic circuit-breakers protect the motor. A contactor with control button ensures Start/Stop switching, provided that the autotransformer is at 0 voltage.
 An indicator signals powering up.
- **Auxiliary single-phase voltage: 0-250VAC 2.5A**
 0-250V variable, by single-phase autotransformer protected against overloads and short-circuits.
 A button provides Start/Stop switching. An indicator signals powering up.
- **Auxiliary DC voltage: 0-250VDC / 2,5A**
 0-250V variable, by single-phase autotransformer with isolating transformer, to standard NFC61558; the set is protected against overloads and short-circuits.
 A button provides Start/Stop switching. An indicator signals powering up.
 Double alternating rectification, with ripple factor varying with the load.
- **Mains three-phase 3 x 400V AC**
 Protected by circuit-breaker. A contactor with control button provides Start/Stop switching. An indicator signals powering up.
- **Mains outlets 230V AC – 2P+E**
 Protected by circuit-breaker. An indicator signals powering up.



OPTIONAL LOADS



RESISTIVE LOAD

- Adjustable from 0 to nominal power
- 6 switches
- Jumpers for coupling
- Power 0.5 or 2 or 4kW

ref. QUICK-RHP40

CAPACITIVE LOAD

- Adjustable from 0 to nominal power
- 6 switches
- Jumpers for coupling
- Power 0.5 or 2 or 4kVAR

ref. QUICK-CH40



"Intelligent Home" energy control system



QUICK-NRJ presented on MODULO-1 frame

The colour touch screen module displays all the detail of consumption, for controlling heating (pilot wire and load shedding), lighting and roller blinds.



EDUCATIONAL OBJECTIVES

- Study a measurement system for energy consumption according to new standard for energy saving.
- Study the principle of a home control installation equipped with DELTA DORE® radio components
- Parameter the DELTA DORE® radio components (RF technology)
- Produce wiring for home components.
- Learn how to use a clamp ammeter.

TEACHING RESOURCES STUDENT & TEACHER

Proposed Practical Works

- Production of the complete wiring diagram.
- Study of the production of the wiring and programming of the components from the DELTA DORE touch screen module
- Study and production of radio commands for lighting, roller blinds and heating.
- Reading of power according to the heating operating cycles.
- Comparison of the power displayed on screen with that calculated from the different readings.
- Creation of scenarios according to the outside temperature and sunshine.

ref. QUICK-NRJ

More and more standards and directives require individual homes to be equipped with a system enabling energy consumption to be measured or estimated. QUICK-NRJ groups all the DELTA DORE® components needed to learn about electrical energy consumption. A colour touch screen module displays all the energy use information as graphs. The different components are prepared in plastic housings engraved and equipped with 4mm terminals to facilitate and make safe the wiring using safety leads. The modules are very easy to install on the aluminium wheeled frame.

Comprises

- 1 Module - data transmitter with off-peak hours control
- 1 Module - colour touch screen displaying all the detail of consumption, for controlling heating (pilot wire and load shedding), lighting and roller blinds.
- 1 Module - 3 current transformers (max 60A) for measuring 3 different circuits.
- 1 Module - power interface technical unit for touch screen.
- 1 Radio module - sunlight sensor.
- 1 Radio module - outside temperature sensor
- 2 Radio modules - roller blind control
- 1 Simulation module - 2 blinds.
- 1 Radio module - lighting variation.
- 1 Radio module - lighting variation, off/on, timing
- 2 Modules - bulkhead lights 230V AC - 60 W
- 3 Modules - load 320 W + indicator lights
- 1 Simulation module - 3 pilot wire convactor heaters, 1 hot water tank and 1 pellet burner.